



Excalibur Water Systems

Commercial/Industrial Products

SYSTEM DESIGN DATA & SPECIFICATIONS

Model: EWS FS2HAG7

Simplex 2"H Turbidity Filter 7ft³

Chemical Removal Filter Operating Parameters

Peak Flow Rate, gpm	: 30.1
Critical Flow Rate (5 Micron)	: 24.1
Critical Flow Rate (1 Micron)	: 9.6
Minimum Flow Rate, gpm	: 4.8
Backwash Flow Rate, gpm	: 36.0
Media Qty, ft ³	: 7.0
#20 Gravel Qty, lbs	: 100.0
Distributor Size, in	: 2.0
Drain Line Size, in	: 1.5

Miscellaneous Design Data

Mineral Tank Size, in.	: 21x62
Tank Area, ft ²	: 2.41
Freeboard, in.	: 19.5
Bed Depth, in	: 34.9
Total Regeneration Time, min.	: 18
Operating Pressure, psi	: 40-110
Operating Temperature, ° F	: 40-110
Shipping Weight, lbs.	: 720
Space Req'd in, L x W x H	: 22 X 23 X 85

Electrical Specifications

Supply Voltage	: 120V AC
Supply Frequency	: 60 Hz
Output Voltage	: 20V AC
Output Current:	: 750 mA

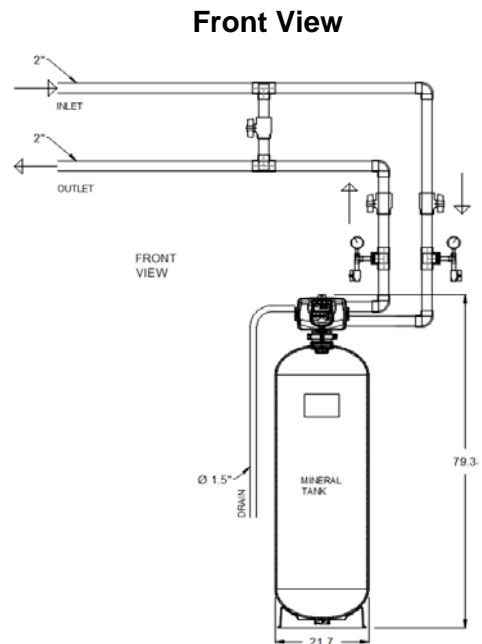
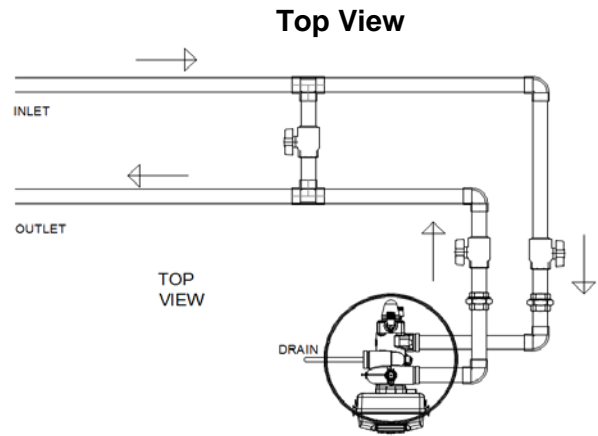

Model: EWS FS2HAG7