

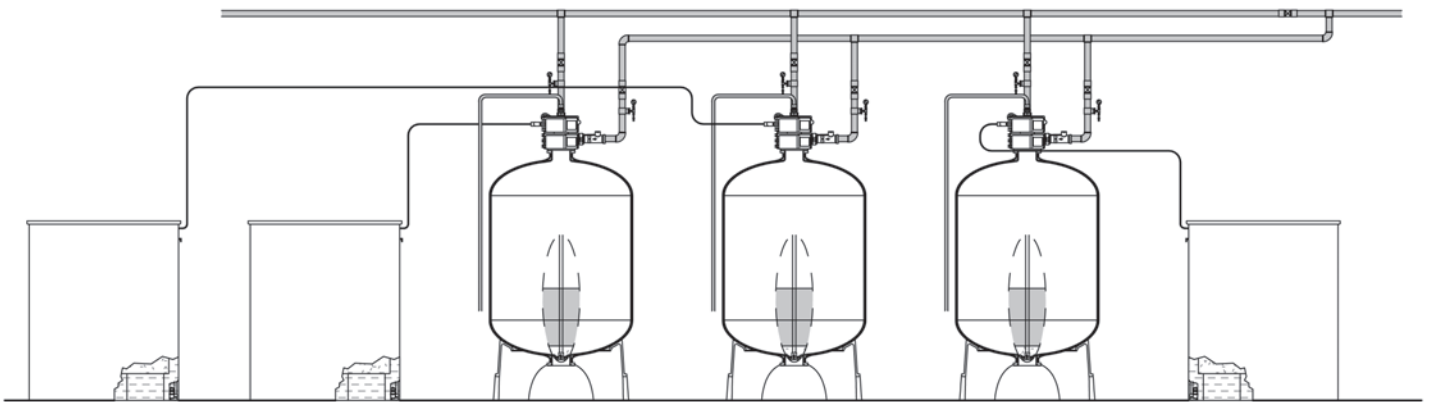

EXCALIBUR WATER SYSTEMS
3.0" HIGH CAPACITY SUPERFLOW SERIES
TRIPLEX WATER SOFTENER
Installation and Operations Manual



**142 Commerce Park Drive,
Units M-O, Barrie ON L4N 8W8**

www.excaliburwater.com

Water Pressure:

All 3" water softeners require a minimum of 25psi of water pressure for regeneration of water softeners to operate effectively.

Electrical Requirements:

All 3" water softeners require 24 volt, 60 Hertz continuous current supply (other voltages are available). Make certain the water softeners current supply is always hot and cannot be turned off with another switch. All water softeners must have a designated wall receptacle to eliminate any power interruptions to the water softener.

Existing Plumbing:

The condition of existing plumbing should be free of scale and iron buildup. All piping that has a heavy buildup of scale and/or iron should be replaced. If piping is clogged with iron, a separate iron filter should be installed ahead of the water softener.

Location of Softener and Drain:

The water softener should be located close to a drain and 3 feet away from electrical panels.

Bypass Valve:

The water softener will always require 3-way or 5-way bypass valves.

CAUTION:

The water softener water pressure is not to exceed 120psi, water temperature not to exceed 110°, and the water softener cannot be subjected to temperatures below 40° F.

Installation Concerns:

- A] Place the water softener tank where you want to install the water softener, making sure the water softener is level and on a firm base, (the water softener must be a maximum of 7 feet apart for Duplex water softeners), to provide the water softener for expansion and contraction of fiberglass resin/media tanks and rigid plumbing load, use flexible fittings at the water softener control valve.
- B] All plumbing to that water softener should be done in accordance with local plumbing codes. The water softener pipe size for the water softener drain line should be the same pipe size as the water softener flow control connection. Water meters are to be installed on water softener outlets. Duplex water softeners with 1 (one) meter shall be installed on common water softener outlet of multiple water softeners.
- C] Make sure that the floor is clean beneath the water softener brine tank and that it is level.
- D] Place in the water softener brine tank approximately 1 (one) inch of water above the grid plate (if used). If grid plate is not used in the water softener brine tank, add 12 (twelve) inches of water to the brine tank. Water softener salt may be placed in the water softener

brine tank at this time.

E] Place the water softener in by-pass position. Turn on the main water supply to the water softener. Open a cold soft water faucet close to the water softener and let it run a few minutes or until the water softener is free from foreign material such as piping solder that may have resulted from the installation of the water softener.

F] Place the water softener bypass in service position.

G] Manually index the water softener control valve into "service" position and let the water flow into water softener mineral tank. When the water softener water flow stops, close the water softener inlet valve, place the water softener control valve in "backwash" position to relieve head of air pressure, then gradually open inlet water softener valve to purge remaining air in water softener mineral tank. Return water softener control valve to "service" position.

H] Electrical:

All water softener electrical connections must be connected according to codes. Use electrical conduit if applicable. Plug water softener into power supply.

Water Softener Flow Diagrams:

Hard water enters the water softener control valve inlet and flows down through the water softener mineral tank to the bottom water softener distributor. The water softener conditioned water flows up through the distributor tube, around the water softener piston and out of the water softener outlet.

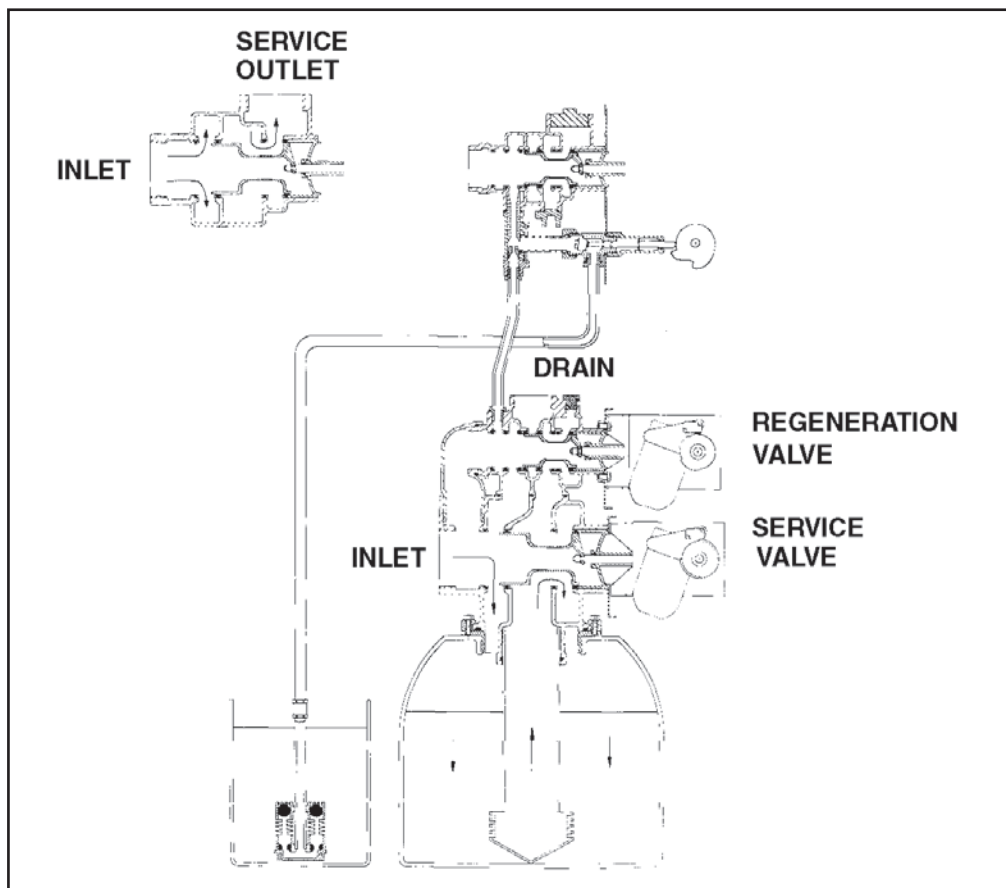

Water Softener Flow Diagrams Continued:

Hard water enters the water softener control valve inlet, flows through service adapter piston for the water softener by-pass and up through coupling to water softener regeneration control valve inlet. Water flows continuously through the water softener regeneration control valve piston down the water softener distributor tube through the water softener media around the water softener piston and out the water softener drain. If the water softener optional no hard water by-pass piston is used, water flow to water softener service outlet is prevented by an extension on the water softener service outlet until the end of the water softener rapid rinse cycle or water softener brine tank refill cycle, depending on water softens chosen.

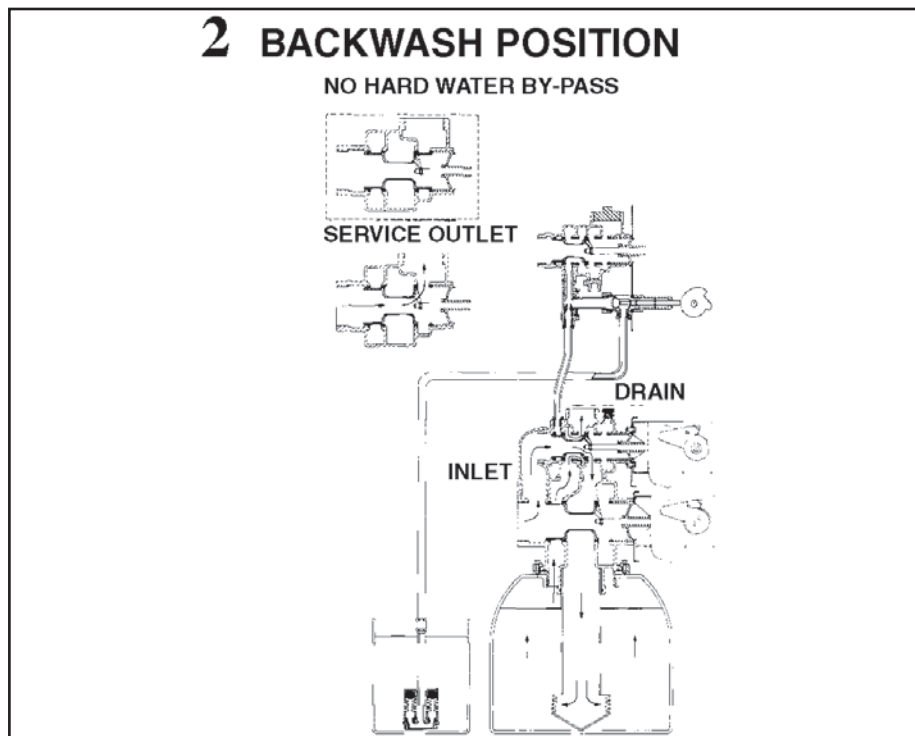

Water Softener Flow Diagrams Continued:

Hard water enters the water softener control valve inlet, flows through injector nozzle and throat to drain water softener brine from the water softener media into the bottom distributor, up the water softener distributor tube and around the water softener piston and out the water softener drain.

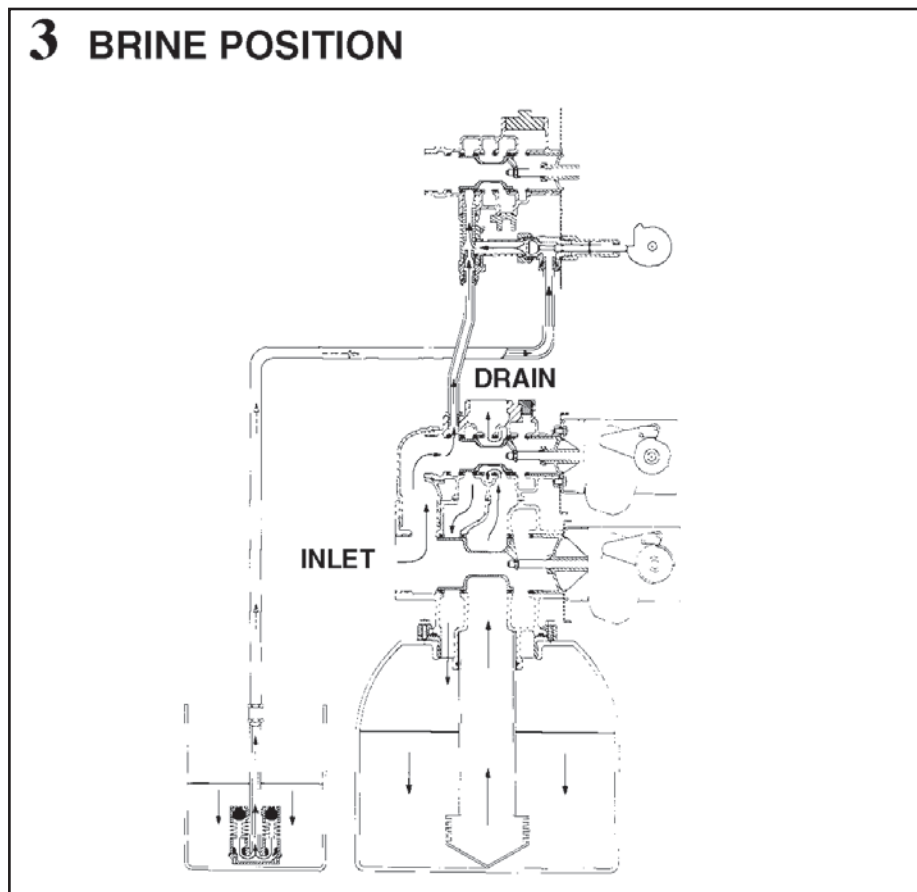

Water Softener Flow Diagrams Continued:

Hard water enters the water softener control valve inlet, flows through injector nozzle and throat, down through the water softener media into the water softener bottom distributor up the water softener distributor tube around the water softener piston and out the water softener drain.

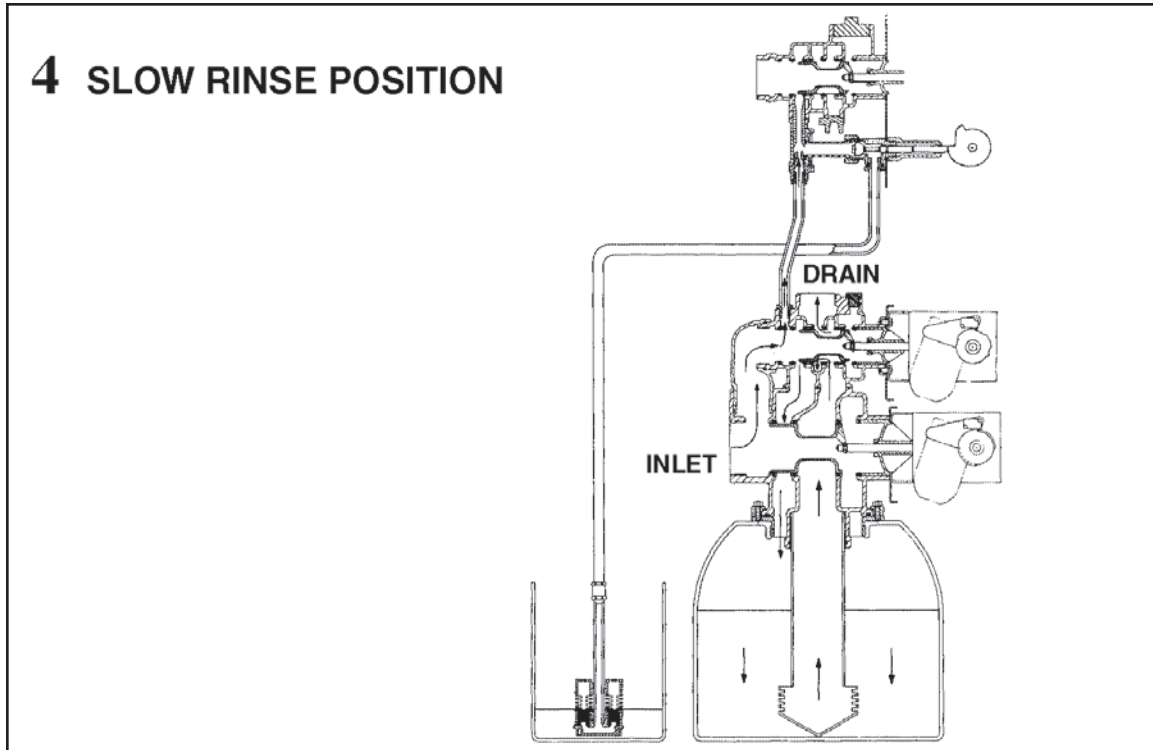

Water Softener Flow Diagrams Continued:

Hard water enters the water softener control valve inlet, flows through the water softener regeneration water softener control valve directly down through the water softener media, into the water softener bottom distributor and up the water softener distributor tube around the water softener piston and out the water softener drain.

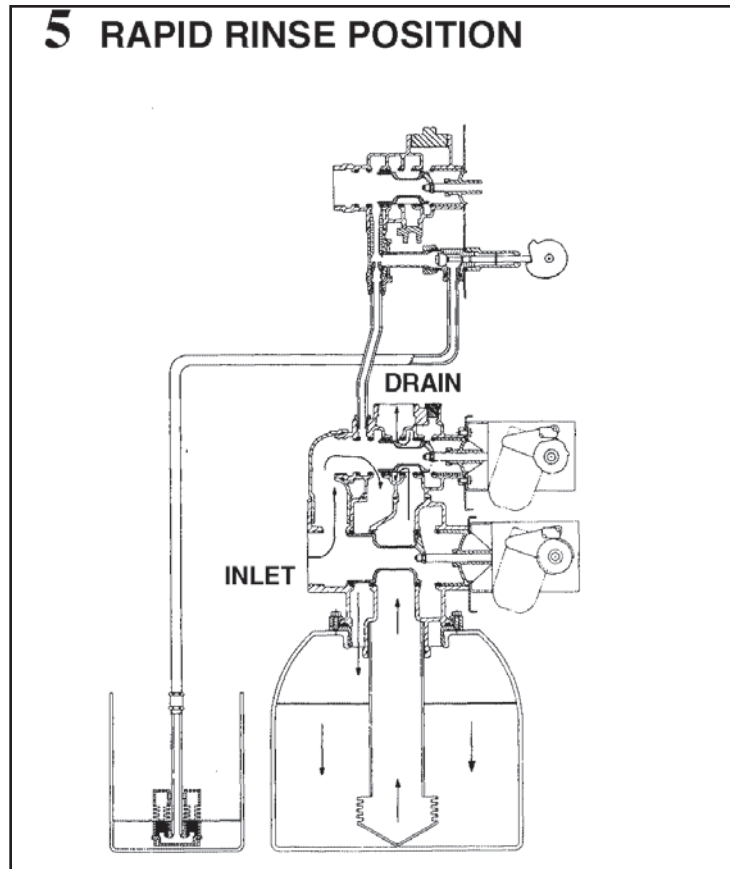

Water Softener Flow Diagrams Continued:

Hard water enters the water softener control valve inlet, flows through the water softener nozzle and throat to the water softener brine valve to refill the water softener brine tank. The water softener inlet flow also continues down through the media to the water softener bottom distributor water softener conditioned water flows up through the water softener distributor tube, around the water softener piston and out of the water softener outlet.

Note:

Water softener option is available to keep service water softener control valve in by-pass position until the end of the water softener brine tank refill cycle.

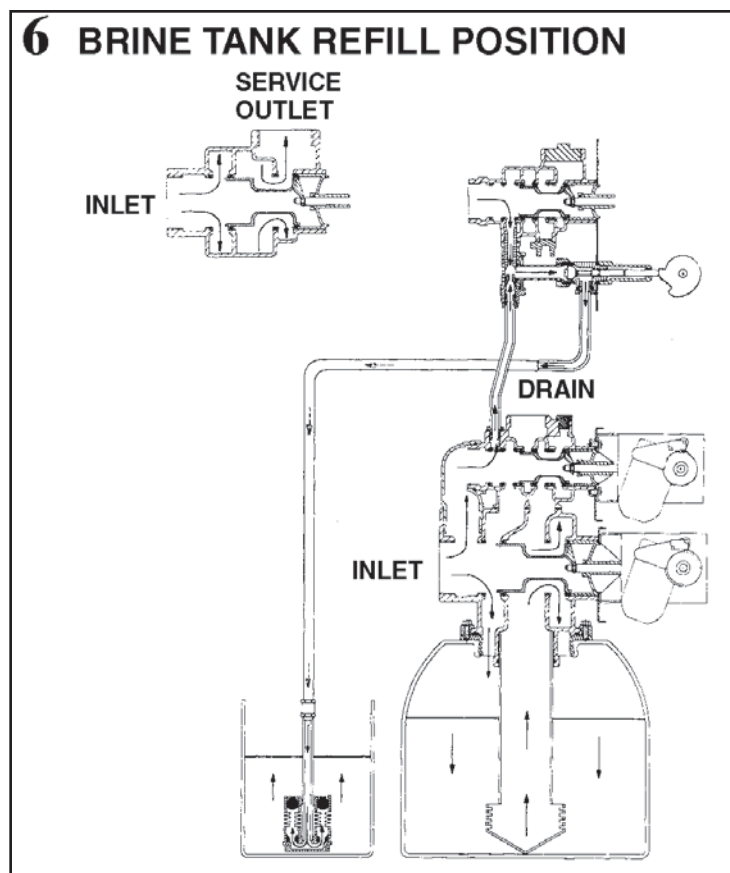

3" Water Softener Electronic Controller:

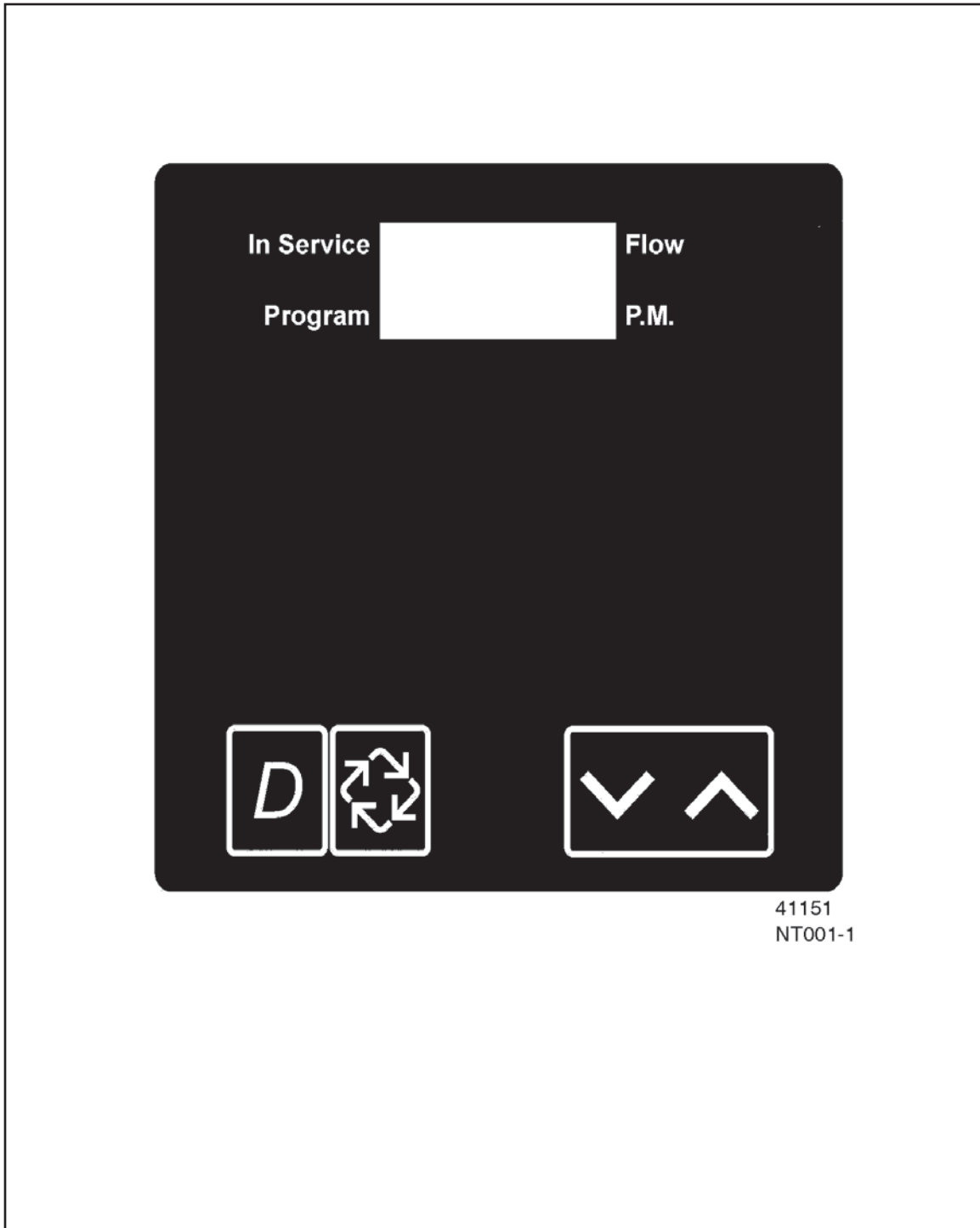

Water Softener Timer Operation:

Set water softener time of day. When the water softener timer is in service, push either the water softener set up or set down button once to adjust the water softener time of day by one digit. Push and hold the water softener to adjust by several digits.

Water softener manually initiating a regeneration:

1. When the water softener timer is in service, press the water softener extra cycle button for 5 (five) seconds for a water softener regeneration.
2. The water softener timer reaches regeneration cycle Step 1.
3. Press the water softener extra cycle button once to advance water softener valve to regeneration cycle step #2 (if active).
4. Press the water softener extra cycle button once to advance water softener valve to regeneration cycle step #3 (if active).
5. Press the water softener extra cycle button once to advance water softener valve to regeneration cycle step #4 (if active).
6. Press the water softener extra cycle button once to advance water softener valve to regeneration cycle step #5 (if active).
7. Press the water softener extra cycle button once more to advance water softener valve back to service.

The Water Softener Timer Operation During Regeneration:

In the water softener regeneration cycle step display, the water softener timer shows the current water softener regeneration step number the water softener valve is advancing to or has reached and the water softener timer remaining in that step. The water softener step number that displays flashes until the water softener valve completes driving to this water softener regeneration step position. Once all water softener regeneration steps are complete, the water softener timer returns to in service and resumes normal water softener operation.

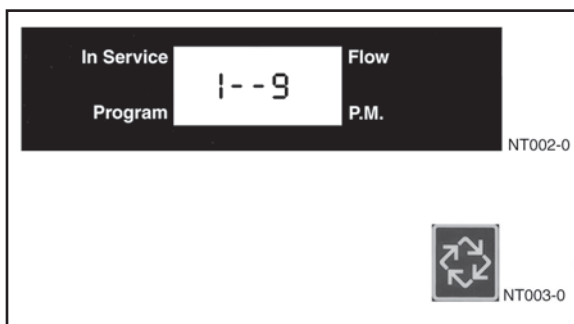

Water softener has less than 10 minutes remaining in water softener in regeneration Step #1

Press the water softener extra cycle button during a water softener regeneration cycle to immediately advance the water softener valve to the next water softener cycle step position and resume normal step timing.

Start a Water Softener Regeneration Tonight:

With water softener metered delayed timers, press the water softener extra cycle button briefly. The water softener in service indicator dot flashes and resume starts a water softener regeneration tonight. At the water softener programmed regeneration time.

Water Softener Day Regeneration:

During water softener normal operation, the time of day display is visible at all times. The water softener timer operates normally until the water softener number of days since the last water softener regeneration reaches the regeneration day override setting. Once this occurs, a water softener regeneration cycle is initiated at the preset regeneration time.

Water Softener Flow Meter Equipped Timer:

During normal water softener operation the time of day display alternates with the volume remaining display (gallons or m³)

- As treated water is used, the water softener volume remaining display counts down from the water softener calculated system capacity to zero or (---). When this occurs, a water softener regeneration cycle begins or delays to the set regeneration time.

Water Softener Immediate Regeneration Timer With Regeneration Day Override Set:

When the water softener control valve reaches the set days since the water softener regeneration override valve, a regeneration cycle initiates at the water softener preset regeneration time. This occurs even if the water softener volume remaining display has not reached zero.

Water Softener Delayed Regeneration Timer With Regeneration Day:

When the water softener control valve reaches the set days since the water softener regeneration override valve, a regeneration cycle initiates at the water softener preset regeneration time. This occurs even if the water softener volume remaining display has not reached zero.

Water Softener Timer Operation During Programming:

The water softener timer only enters the water softener program mode with the water softener timer in service. While the water softener is in program mode, the water softener timer continues to operate normally monitoring water usage and keeping all water softener displays up to date. The water softener timer programming is stored in the water softener memory permanently. There is no need for water softener battery backup power.

Water Softener Timer Operation During a Power Failure:

During a power failure, all water softener timer displays and programming are stored for use upon power re-application. The water softener timer retains all values, without loss. The water softener timer is fully inoperative any calls for water softener are delayed. The water

softener timer, upon power re-application, resumes normal operation from the point that the water softener was interrupted.

Note:

An accurate water softener time of day may indicate a power outage.

Water Softener Remote Lockout:

The water softener timer does not allow the water softener system to go into regeneration until the water softener regeneration lockout input signal to the water softener is cleared. This requires a water softener contact closure to activate. The recommended water softener gauge wire is 20 with a maximum length of 500 feet.

Water Softener Remote Signal Start Regeneration:

The water softener control valve monitors treated water other than a flow meter. When the water softener timer receives a contact closure for the water softener programmed amount of time, the water softener regeneration begins. The recommended water softener gauge wire is 20 with a maximum length of 500 feet.

Water Day Override Feature:

If the water softener day override option is turned on and the water softener control valve reaches the set regeneration day override value without the water meter initiating a water softener regeneration cycle, a water softener regeneration cycle queues. This occurs regardless of the water softener remaining volume available.

Water Softener System 4:

Water softener timer clock (1 water softener valve)

During the water softener normal operation, the time of day display may be viewed at all times. The water softener control valve operates normally until the number of days since the water softener last regeneration reaches the regeneration day override setting. Once this occurs, a water softener regeneration cycle initiates at the present regeneration time.

Water Softener Metered Delayed (1 water softener control valve):

During the water softener normal operation the time of day display alternates with the water softener volume remaining display (gallons or m³)

- As treated water is used, the water softener volume remaining display counts down from the water softener calculated system.
- The water softener system monitors the water softener volume of water used. When the water softener calculates that there is not sufficient capacity for the water softener next day's operation, a water softener regeneration cycle is initiated at the water softener at the present regeneration time.
- Water flow through the water softener control valve is indicated by the 4 flow dot that lashes in a direct relationship to flow rate.

Water Softener Meter Immediate (1 water softener control valve):

During the water softener normal operation the water softener time of day display alternates with the water softener volume remaining display (gallons or m³)

- As treated water is used, the water softener volume remaining display counts down from the water softener capacity to zero or (---). When this occurs, a water softener regeneration cycle is started.
- Water flow through the water softener control valve is indicated by the flow dot that flashes in a direct relationship to flow rate.

Water Softener System 5:

Water softener interlock (2-4 water softener control valves)

During water softener normal operations the water softener time of day display (gallons or m³)

- As treated water is used the water softener volume remaining display counts down from the water softener calculated system capacity to zero or (---). When this occurs, a water softener regeneration cycle queues.
- If no other water softener control valve is in regeneration, the water softener valve sends a lock command and starts a regeneration cycle.
- If another water softener control valve is in regeneration (i.e. the water softener system is already locked) the water softener valve remains in service with regeneration queues until other water softener control valves complete regeneration. Then the water softener system locks and regeneration begins.
- Water flow through the water softener control valve is indicated by the flow dot that flashes in a direct relationship to flow rate.

Water Softener System 6 (2-4 water softener valves):

During normal operation, the water softener time of day display alternates with the water softener volume remaining display (gallons or m³). The water softener volume remaining is the total volume for all water softeners in the system.

- As treated water is used, the water softener volume remaining display counts down from the water softener calculated system capacity to zero or (---). When this occurs, a water softener regeneration queues.
- If no other water softener control valve is in regeneration the lead water softener control valve sends a lock command and starts a water softener regeneration cycle.
- When the lead water softener control valve completes regeneration cycle, the water softener remaining water softener control valves in the system regenerate sequentially until all water softeners regenerate.
- Water flow through the water softener control valve is indicated by the flow dot that flashes in a direct relationship to the flow rate.
- Lag water softener control valve volume remaining is updated every 5 seconds from the lead water softener control valve.

- A manually forced water softener regeneration (ECKEY) can only be done on the lead water softener control valve and only if the water softener system is not in regeneration.

Water Softener System 7 Alternating (2 valve water softener):

During normal water softener operation the time of day display alternates with the water softener volume remaining display (gallons or m³). The water softener volume remaining is for the individual water softener.

- As treated water is used, the water softener remaining volume counts down from the water softener calculated capacity to zero or (---). When this occurs, a water softener regeneration cycle queues.
- The water softener control valve requiring regeneration sends a lock command to the standby water softener control valve. The standby water softener control valve goes in to service and exhausted water softener starts a regeneration cycle.
- If a water softener control valve is in regeneration and the other water softener exhausts its volume remaining, then the exhausted water softener remains in service with regeneration queued until the other water softener goes into standby. The exhausted water softener goes into standby after completing regeneration water flow through the water softener control valve is indicated by the flow dot that flashes in a direct relationship to flow rate.

Water Softener System 9 Alternating(2-4 water softeners):

During normal water softener operation the time of day display alternates with the water softener volume remaining display (gallons or m³). The water softener volume remaining is for the individual water softener.

- As treated water is used, the water softener remaining volume counts down from the water softener calculated capacity to zero or (---). When this occurs, a water softener regeneration cycle queues.
- The water softener control valve requiring regeneration sends a lock command to the standby water softener control valve. The standby water softener control valve goes in to service and exhausted water softener starts a regeneration cycle.
- If a water softener control valve is in regeneration and the other water softener exhausts its volume remaining, then the exhausted water softener remains in service with regeneration queued until the other water softener goes into standby. The exhausted water softener goes into standby after completing regeneration.
- All water softeners remain in service except those in standby or regeneration.
- Water flow through the water softener control valve is indicated by the water softener flow dot that flashes in a direct relationship to flow rate.

Important Water Softener System Operation Tips:

- When programming muti water softener systems, program lag water softener first and then lead water softener. This eliminates or minimizes program and communication errors.
- When changing a water softener valve from one water softener system type to another water softener system type, perform a master reset first.

- Water softener system 6, 7 and 9 control valves coming out of water softener program mode or on power-up calculate their volume (display – calc) and then wait for a good communication signal.
- When a good communication signal is received, the water softener system resumes normal operations.
- If the water softener system does not receive a good communication signal, calc displays and the water softener system goes into a wait. Press ECKEY to force the 4 water softener out of the wait and resume normal operation. A communication error may appear after one minute.
- The water softener system 4, 5 and 6 lead water softener valve drive sequence going into regeneration is:
 - The lower water softener drive moves to off-line and the upper water softener drive moves to first regeneration position.

All Water Softener Systems 7 and 9:

- The offline water softener moves to online, the water softener requiring regeneration moves its lower water softener drive to offline and then upper water softener moves to first regeneration position.
- Water softener reserve capacity – system 4Fd only. After water softener power up or master is reset, the water softener reserve is set by using the safety factor. The water softener reserve is limited to a range of 0% - 50% of the water softener capacity.
- Water softener system 6 and 7, lead water softeners only, respond to remote lock and chemical pump. Also, chemical pump is available only if the water softener relay in regeneration is not used (AroF).

Water Softener Timer Operation:

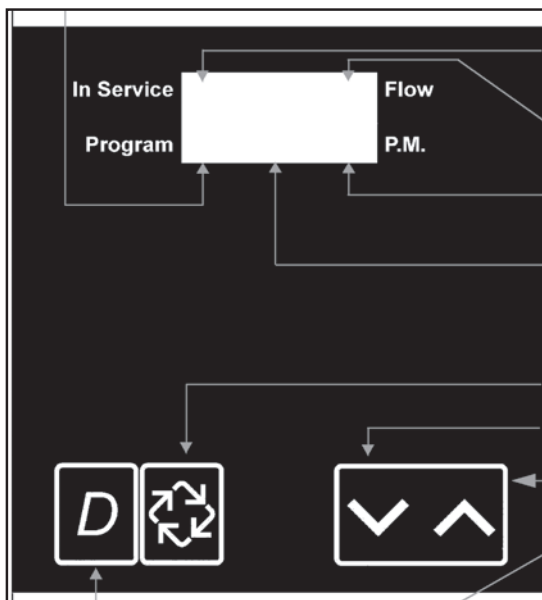

Water Softener Program Indicator

Programming mode active, light on

Water Softener Service Indicator

Water softener time in service. Light on, regenerate tonight, flashing light.

Water Softener Flow Indicator

No water flow, light off, water flow, light flashing

Water Softener PM Indicator

PM light on, AM light on

Water Softener Display Screen

Water softener time of day alternates with water softener process display. example; volume remaining, time remaining, programming information.

Water Softener Extra Cycle Button

Water softener valve in regeneration - light on

Water Softener Set Down Button

Adjust water softener valve down.

Water Softener Set Up Button

Adjust water softener valve up.

Water Softener Diagnostic Button

View flow rate, peak flow rate, totalizer, hours between last two water softener regenerations, hours since last water softener regeneration, adjustable volume remaining, water softener valve positions, software version.

1. Enter water softener 3200NT programming mode:



Press the water softener button and hold both the setup and the set down buttons for five seconds to enter programming mode. When the program mode is entered, the program light illuminates.

2. Set feed water softener hardness:



The water softener feed water hardness setting displays only if the regeneration type is set to water softener meter immediate or meter delayed.



Press the water softener set up and set down buttons to set the amount of water softener feed water hardness (in grains/gallons) the water softener automatically calculates water softener treated water capacity based on the feed water hardness and the water softener system capacity.



Press the water softener extra cycle button to proceed to the water softener next step.

3. Set water softener regeneration time:



A non-flashing colon between two sets of water softener numbers identifies the water softener regeneration time display. Set the water softener desired time of day that you want regeneration to occur.



Press the water softener set up and set down buttons to adjust the water softener valve.



Press the water softener extra cycle button to proceed to the day override.

4. Set water softener regeneration day override:

Use this water softener display to set the maximum amount of time (in days) the water softener can be in service without a water softener regeneration.

For water softener system 4, time clock water softener regeneration mode the water softener system regenerates at the time set in Step 4. After the water softener number of days programmed in this step.

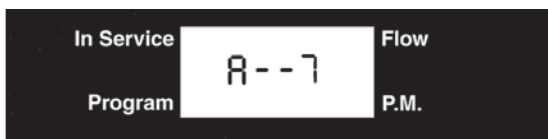

For all other water softener system types (meter immediate, meter delayed 5, 6, 7, 9) the water softener system regenerates after the water softener number of days programmed in this step unless the water softener meter initiates a regeneration cycle earlier.



Press the water softener extra cycle button to proceed to the water softener next step.

Water softener timer programming is complete and exits from the water softener programming mode. Normal water softener operation resumes.

Water Softener Master Programming Flow Chart

Note:

1. Set water softener time of day to 12:01 PM
2. Press and hold both the water softener set up and set down buttons for 5 seconds.
3. Press the water softener extra cycle button once per display until all displays are viewed and normal display is resumed.
4. Optional water softener setting displays may be changed as required by pressing water softener either the set up button or set down button.
- 5 Depending on current water softener valve programming, certain displays may not be viewed or set.

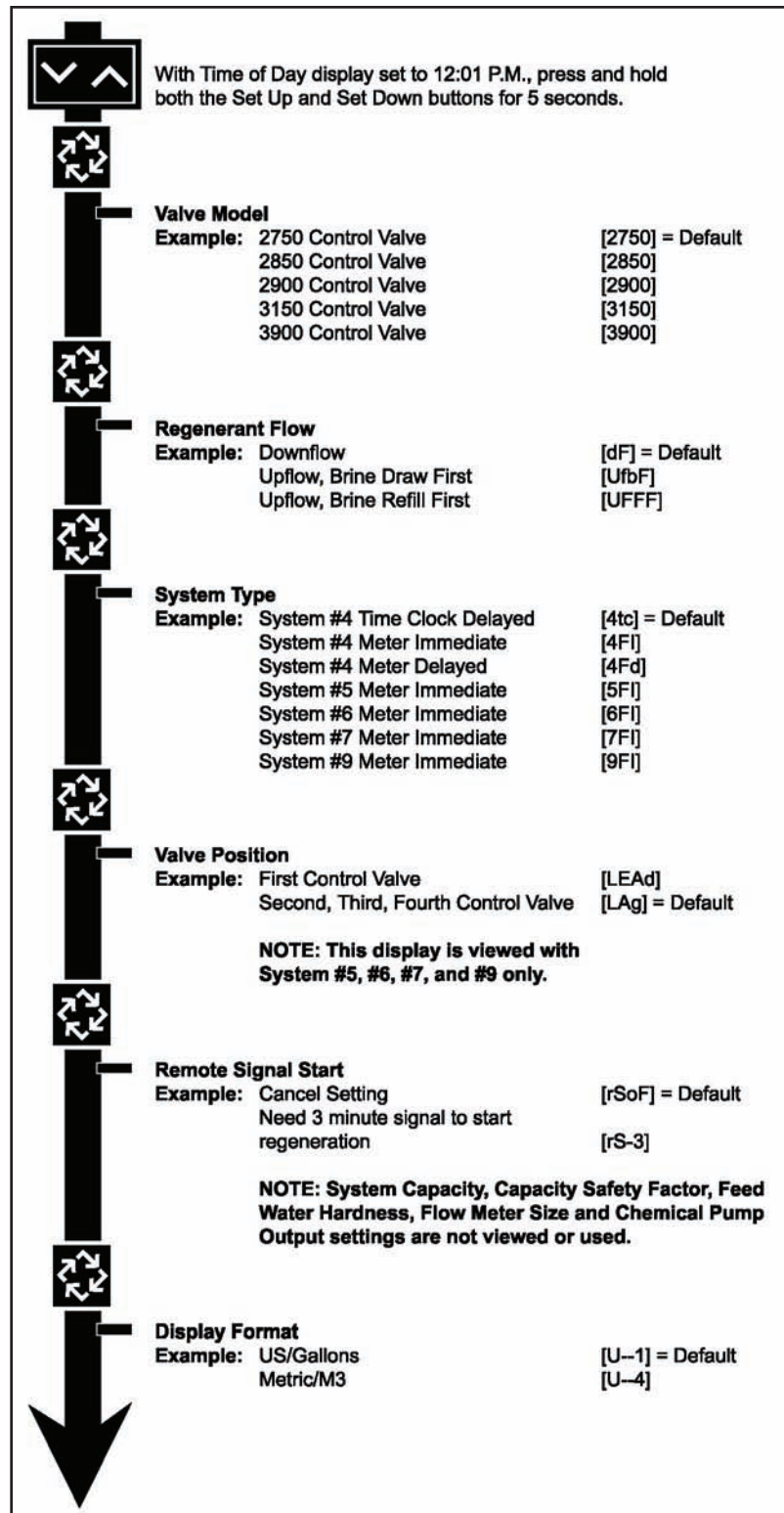

Water Softener Master Programming Flow Chart

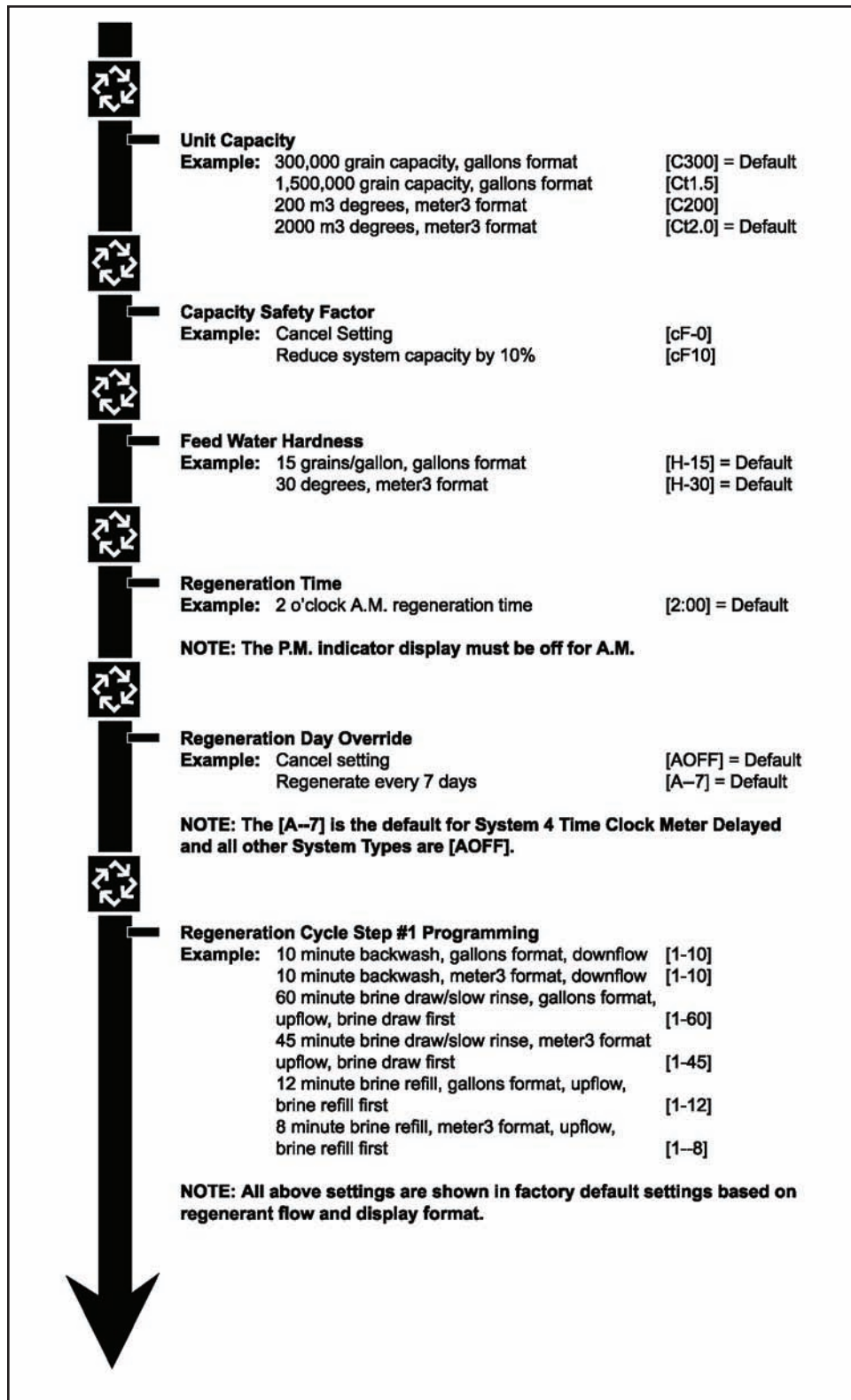

Water Softener Master Programming Flow Chart

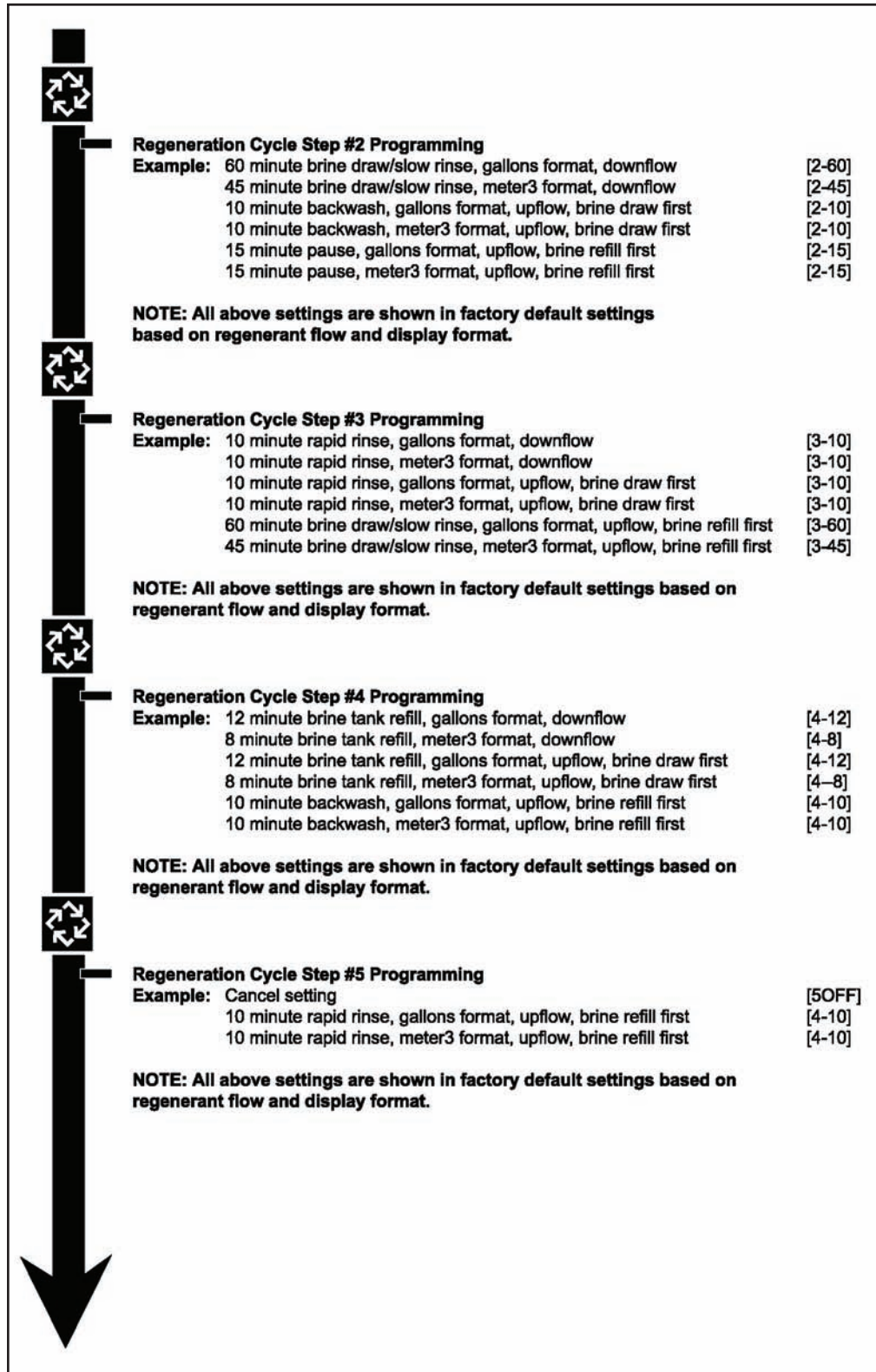

Water Softener Master Programming Flow Chart

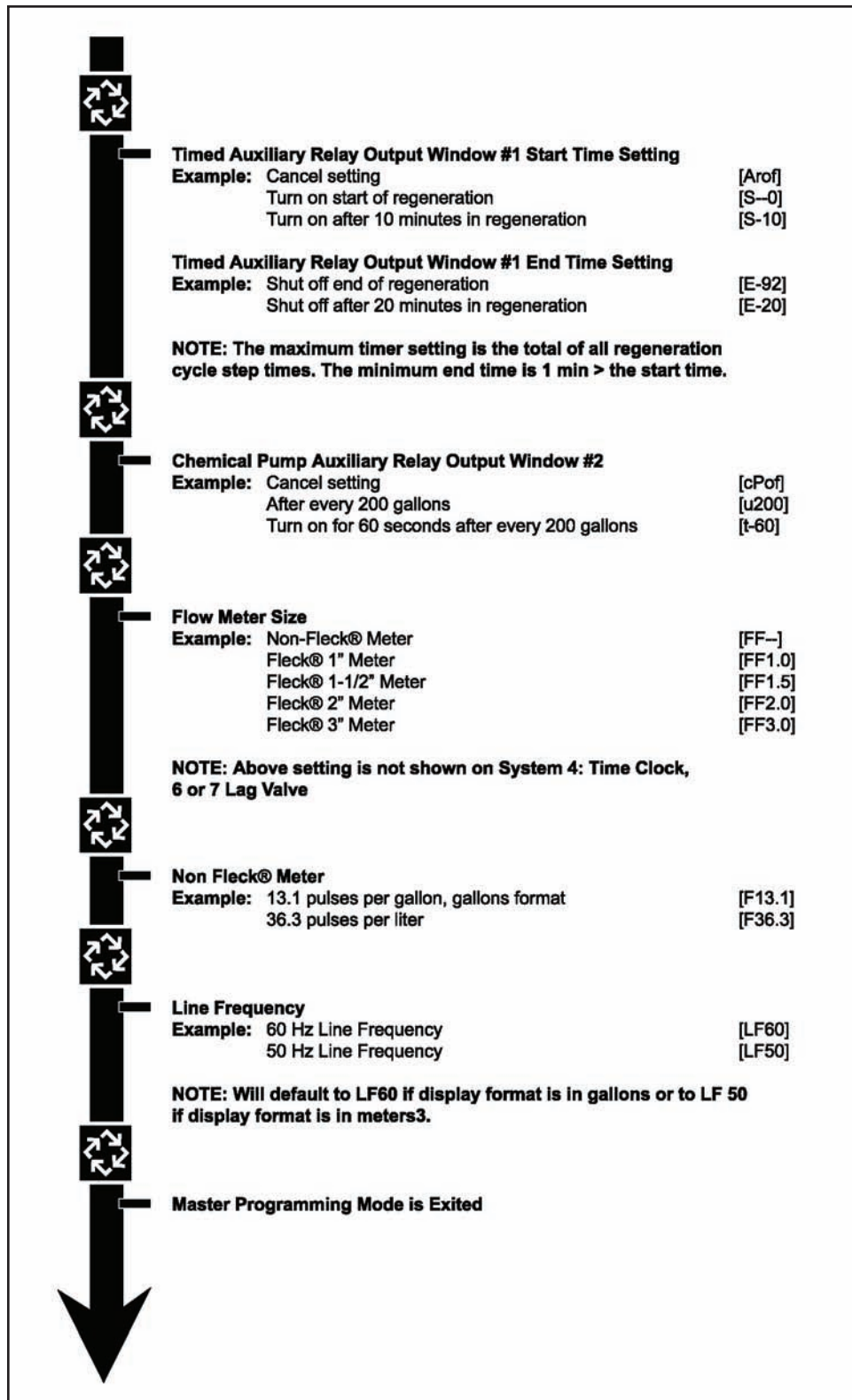

Water Softener Master Programming Flow Chart

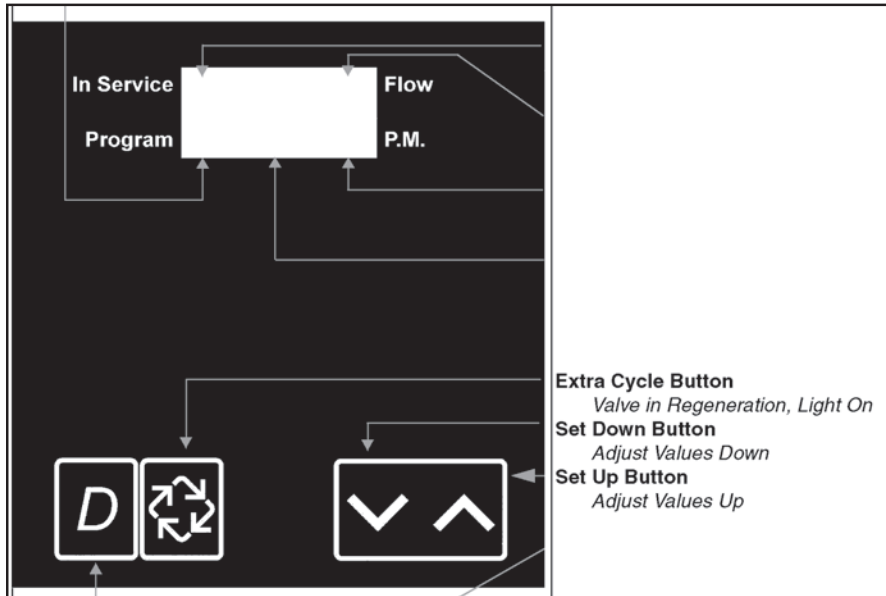

When the water softener master programming mode is entered, all available water softener option setting displays may be viewed and set as needed. Depending on current option settings, some water softener displays cannot be viewed or set.

Entering Water Softener Master Programming Mode:

Set the water softener time of day display to 12:01 PM. Press and hold the water softener set up and set down buttons together until the program indicator turns on (about 5 seconds). Depending on current water softener option settings, some water softener displays cannot be viewed or set.

Exiting Water Softener Master Programming Mode:

Press the water softener extra cycle button once per display until all water softener are viewed. The water softener program mode is exited and normal displays resume.

Resetting Water Softener Permanent Programming Memory:

Press and hold the water softener set up and set down buttons (for about 25 seconds) until the water softener time of day display resets to 12:00 PM. All water softener option settings reset to default values. Water softener control programming must be reset as necessary.

1. Water softener valve mode (no display code). This water softener program step selects water softeners valve model.

- Use water softener set up and set down buttons to adjust this valve.
- Press the water softener extra cycle button.

2. Water softener regenerant flow (no display code). This water softener program step is used to set the water softener regeneration type. Availability is dependent on the water softener model chosen.

Water softener down flow, setting (dF)

Water softener up flow, brine first setting (UFBF)

Water softener up flow, fill first setting (UFFF)

- Use water softener set up or set down buttons to adjust this valve.

- Press the water softener extra cycle button.

Water Softener Master Programming Mode

3. Water softener system type. Use this water softener program step to set the water softener system type. Possible settings are:

Water Softener Type 4 Time Clock Delayed Setting (4TC):

The water softener control regenerates on the days set in water softener day override, at the water softener regeneration time set in the water softener time.

Water Softener Type 4 Meter Immediate Setting (4FI):

The water softener control regenerates immediately when the available volume of treated water drops to zero.

Water Softener Type 4 Meter Delayed Setting (4FD):

The water softener control regenerates on the day the available volume of treated water drops to less than the water softener reserve volume. The water softener regeneration starts the regeneration time.

Water Softener System Type 5 Meter Immediate (Interlock) Setting (5F1):

This is a 2 to 4 water softener system, each water softener having a meter, all water softeners in service. Only one water softener is allowed in regeneration at a time. A water softener regenerates immediately when the available volume of treated water drops to zero (0) and no other water softener is in regeneration.

Water Softener System Type 6 Meter Immediate (Series) Setting (6F1):

This is a 2 to 4 water softener system, all water softener in service, with one meter for the entire water softener system. When the entire water softener system volume of treated water drops to zero (0), it requests the first water softener to go into regeneration. Then when the first water softener is done regeneration, the second water softener follows and so on...

Water Softener System 7 Meter Immediate (Alternating) Setting (7F1):

This is a 2 water softener system, with only one water softener having a meter and only one water softener in service. When the water softener volume of treated water drops to zero (0) in the water softener in service, it requests regeneration. This causes the water softener in standby to move to service. Then the water softener requesting regeneration moves to standby and begins regeneration.

Water Softener System 9 Meter Immediate (Alternating) Setting (9F1):

This is a 3 or 4 water softener system, each water softener having a meter, one water softener in standby and all other water softeners in service. Only one water softener is allowed in regeneration at a time. When the water softener volume of treated water drops to zero in the water softener in service, it requests water softener regeneration. This causes the water softener in standby to move to service. Then the water softener requesting regeneration moves to standby and begins regeneration.

- Use water softener set up or set down buttons to adjust this valve.
- Press the water softener extra cycle button.

4. Water Softener Valve Position (No display Code):

This water softener program step is for two or more water softeners in a system. Enter lead on the first water softener in a system, and the remaining enter lag. For water softener systems that use 1 meter, the water softener flow meter cable must be connected to the lead water softener. This water softener program step is skipped water systems 4TC and 4FD.

| | |
|--|----------------|
| First water softener | Setting (Lead) |
| Second, third & fourth water softeners | Setting (Lag) |

5. Water Softener Remote Signal Start (Display Code RS):

This water softener is monitored other than a meter. Regeneration begins immediately after a contact closure is received for the water softener number of minutes programmed. The amount of time is required for a contact closure to be presented before the water softener signal is considered to be valid.

| | |
|---|----------------|
| Water softener range = 1-99 minutes | Setting (RSOF) |
| Water softener cancel setting | Setting (RS-3) |
| Water softener 3 minute signal time to start regeneration | |

- Use water softener set up or set down buttons to adjust this value.
- Press the water softener extra cycle button.

6. Water Softener Gallons/Meter 3 Display Format (Display Code U):

This water softener program step sets the desired display format. The letter "U" in the first digit of the display identifies this program step. The possible settings include:

Water softener gallons of water, 12 hour timekeeping and grains of hardness Setting (U - - 1)

Water softener M3 of water, 24 hour timekeeping and degrees of hardness Setting (U - - 4)

- Use water softener set up or set down buttons to adjust this value.

- Press the water softener extra cycle button.

7. Water Softener Capacity (Display Code C):

This water softener program step sets the capacity of the water softener system in kilograins (or $m^3 \times \text{degrees}$ for metric water softener systems). The letter "C" in the first digit of the water softener display identifies this program step. Water softener system capacity calculates the amount of treated water (gallons or litres) that can be treated by the water before a regeneration cycle is required.

Water softener range = C - - 9 – C999 kilograins (US) (U - - 1)

Water softener range = C + 1.0 – C + 2.9 thousands of kilograins or millions of grains (US) (U - - 1)

Water softener range = C199 – C999 $m^3 \times \text{degrees}$ (metric) (U - - 4)

Water softener range = CT1.0 – CT10 kilo $m^3 \times \text{degrees}$ (metric) (U - - 4)

450,000 grain system capacity US display settings (C450)

- Use water softener set up or set down buttons to adjust this value

- Press the water softener extra cycle button

8. Water Softener Capacity Safety Factor (Display Code CF):

This water softener program adjusts capacity. The water softener setting is a percentage by which the water softeners capacity is reduced.

Water softener range = 0 - 50%

Reduce system capacity by 10% Setting (CF10)

- Use water softener set up or set down buttons to adjust this value.

- Press the water softener extra cycle button.

9. Water Softener Feed Water Hardness (Display Code H):

This water softener program sets the feed water hardness. The letter "H" in the first digit of the display identifies this program step. The water softener system automatically calculates treated water capacity based on the feed water hardness entered in this program step and the water softener system capacity in program step #3.

Water softener range = 1 – 199 grains/gallon (US) (U - - 1)

Water softener range = 2 – 199 degrees (Metric) (U - - 4)

20 grains/gallons Setting (H - 20)

- Use water softener set up or set down buttons to adjust the value.

- Press the water softener extra cycle button.

10. Water Softener Regeneration Time (No Display Code):

This water softener program step sets time of day for the water softener regeneration to occur. A non-flashing colon between two sets of water softener numbers identifies the water softener regeneration time display.

Water softener range = any time setting (2:00) (PM indicator OFF)
Water softener 2 AM regeneration time.

- use water softener set up and set down buttons to adjust the value.
- press the water softener extra cycle button.

11. Water Softener Regeneration Day Override (Display Code A):

This water softener program step sets the maximum amount of time (in days) the water softener can be in service without a water softener regeneration. The letter "A" in the first digit of the water softener display identifies this program step. For water softener system type time clock delayed (4TC) the water softener system regenerates at the time set in program step #5. After the number of days programmed in this step, for any water softener meter types, the water softener system regenerates after the number of days programmed in this step at the same time of day that the previous regeneration occurred unless the water softener meter initiates a water softener regeneration cycle earlier.

Water softener range = 1 - 99 (time clock delayed) (4TC)
Water softener range = OFF, 1 - 99 (all meter regeneration types)
Water softener override every 14 days setting (A - 14)
Water softener option turned off setting (AOFF)

- use water softener set up and set down buttons to adjust this value.
- press the water softener extra cycle button.

12. Water Softener Regeneration Cycle Step Programming (Display Code 1 - 6):

This water softener program step programs the regeneration cycle step times. The water softener can do up to 6 regeneration cycles. Steps can be programmed. The water softener regeneration cycle step being programmed is shown in the first digit of the display. Each water softener display sets the duration time in minutes of that specific step in the water softener regeneration cycle. For the water softener regeneration programs with less than six water softener regeneration cycle steps, the time for the step # after the last active step must be set to off. To skip a water softener regeneration cycle step and go to the next cycle, the water softener setting should be at zero (0). If the water softener regeneration cycle step setting is off, the remaining cycle steps will not appear to set.

Water softener range = OFF, 0 - 99 minutes (US) (U - - 1)
Water softener range = OFF, 0 - 99 minutes (Metric) (U - - 4)
Water softener regeneration cycle step #1 (10 minutes) Setting (1 - 10)
Water softener regeneration cycle step #4 (cancel) Setting (4OFF)

- use water softener set up and set down buttons to adjust this value.
- press the water softener extra cycle button.

13. Water Softener Auxiliary Relay Output (Display Codes AROF, CPOF):

The next two water softener displays viewed are part of a series of settings used to program the optional relay output. The first water softener settings turns the outputs ON/OFF during the water softener regeneration only. The second turns the output on during service only,

when a set water softener volume of water used has accumulated. This second is not viewed on non-metered water softener systems. When more than one of these water softener settings is used, the water softener relay must be wired to the auxiliary brine cam switch output to operate two separate pieces of equipment at one time.

Note: When auxiliary water softener outputs are in the OFF (default) setting, use the water softener set up or set down buttons to set the first setting. Then press the water softener extra cycle button to advance to the second setting.

A) Water softener Timed Auxiliary Relay Output (Display Codes S - Start Time, E - End Time). This water softener option setting consists of two displays. The first water softener display sets the turn - ON time of the output. Referenced to the start of the first water softener regeneration cycle. The second water softener display sets the output turn - OFF time, referenced again to output timing, is synchronized with water softener cycle timing.

Water softener range = Total time of regeneration water softener cancel Setting (AROF)

Water softener turn on start of regeneration (S - - 0)

Water softener shut off end of regeneration (E - 92)

Water softener turn on after 10 minutes in regeneration (S - 10)

Water softener turn on after 20 minutes in regeneration (E - 20)

Note: The end of water softener regeneration is the total of all water softener regeneration cycle steps times.

B) Water softener Chemical Pump Output (Display Codes U - Volume, T - Seconds)

The water softener option setting consists of two displays. The first water softener display sets the volume of water flow at which the output turns on. The second water softener display sets the turn ON time (in seconds) of the output.

Water softener range = 1 - 999 gallons

Water softener range = 1 - 999 seconds

Water softener cancel (CPOF)

Water softener active output after every 200 gallons (U200)

Water softener turn ON for 60 seconds after 20 minutes in regeneration (T - 60)

- use water softener set up and set down buttons to adjust this value.

- press the water softener extra cycle button.

14. Water Softener Flow Meter Size (Display Code FF):

This water softener program step sets the sizes of the flow meter. The letters "FF" in the first two digits of the water softener display identifies this program step. The last two digits of the water softener display indicates the meter's size. If (FF - -) generic is chosen, the next step is generic flow meter size. If any other selection is chosen the next step is line frequency.

Water softener range = 3" meter

- use water softener set up and set down buttons to adjust this value.

- press the water softener extra cycle button.

Water Softener Generic Flow Meter Size (Display Code F):

This water softener program step sets the proper number of pulses generated by the flow meter for each gallon or litre of water flow.

- use water softener set up and set down buttons to adjust this value.
- press the water softener extra cycle button.

Water Softener Line Frequency (Display Code LF):

This water softener program step sets the frequency of the power supply. When the line frequency is properly set, all water softener timekeeping functions remain accurate. The letters "LF" in the first digit of the water softener display identify this program step. The possible settings are:

Water softener 60Hz line frequency setting (LF60)

Water Softener Exiting The Master Programming Mode:

Press the water softener extra cycle button once more to exit master program mode. After leaving the water softener master programming mode, the abbreviation CALC appears on the water softener display indicating that the water softener volume is being calculated (initial communication is taking place if the water softener system type is 7 or 9).

Note: The length of time CALC displays is dependent on the calculated volume and could be a minute or more.

Water Softener Time of Day:

Finish the water softener control programming by setting the time of day. While the water softener controller in normal water softener operation mode (not in water softener master programming) or user programming mode, set the water softener time by pressing set up or set down buttons.

Note: Do not press the water softener extra cycle button after setting the water softener time or a water softener regeneration cycle may be initiated.

Verify the following water softener menu structure for each water softener system type. An "X" indicates that parameter is available (note parameters before water softener system type are not included here).

| Parameter | 4tc | 4FI | 4Fd | 5FI | 6 & 7 | 6 & 7 | 9FI |
|---|-----|-----|-----|----------|-------|-------|----------|
| Valve Position (Lead or Lag) | | | | Lead/Lag | Lead | Lag | Lead/Lag |
| Remote Start (Set to rSoF) | | X | | X | X | | X |
| Display Format (U--x) | X | X | X | X | X | X | X |
| System Capacity (Cxxx) | | X | X | X | X | X | X |
| Capacity Safety Factor | | X | X | X | X | X | X |
| Feed Water Hardness | | X | X | X | X | | X |
| Regeneration Time (xx:xx) | X | X | X | X | X | X | X |
| Regeneration Day Override (Axxx) | X | X | X | X | X | X | X |
| Regeneration Cycle Step Times (1-xx, 2-xx, etc) | X | X | X | X | X | X | X |
| Auxiliary Relay (AroF) | X | X | X | X | X | X | X |
| Chemical Pump Output (cPOF) | | X | X | X | X | | X |
| Flow Meter Size (FFxx) | | X | X | X | X | | X |
| Line Frequency (LFxx) | X | X | X | X | X | X | X |

Water Softener Operation Display Definitions and Examples:

Time of Day

Format = US/Gallons



NT005-0

Format = Metric/Meter³

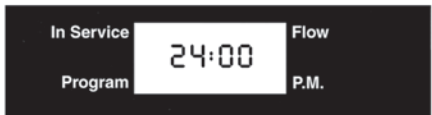

NT007-0

Volume Remaining

L = Display Code (X 1,000,000)

Range = 1,000,000 - 2,900,000



NT020-0

t = Display Code (X 1000)

Range = 10,000 - 999,999



NT021-0

No Display Code

Range = 1 - 9,999



NT022-0

Zero



NT009-0

Calculating the Volume Remaining



Communication Error



Programming Error



Timer is Locked Out



Remote Signal Start Signal is Comm



Remote Lock Out Signal Is On



Water Softener Diagnostic Programming Mode Flow Chart:

Note:

1. Push and release the “D” water softener button.
2. Press the water softener extra cycle button once per water softener display until all water softener displays are viewed and normal water softener display is resumed.
3. Press and release the water softener “D” button at anytime during diagnostic mode and the water softener timer will exit the mode.
4. Depending on current water softener value programming certain water softener displays may not be able to be viewed or set.

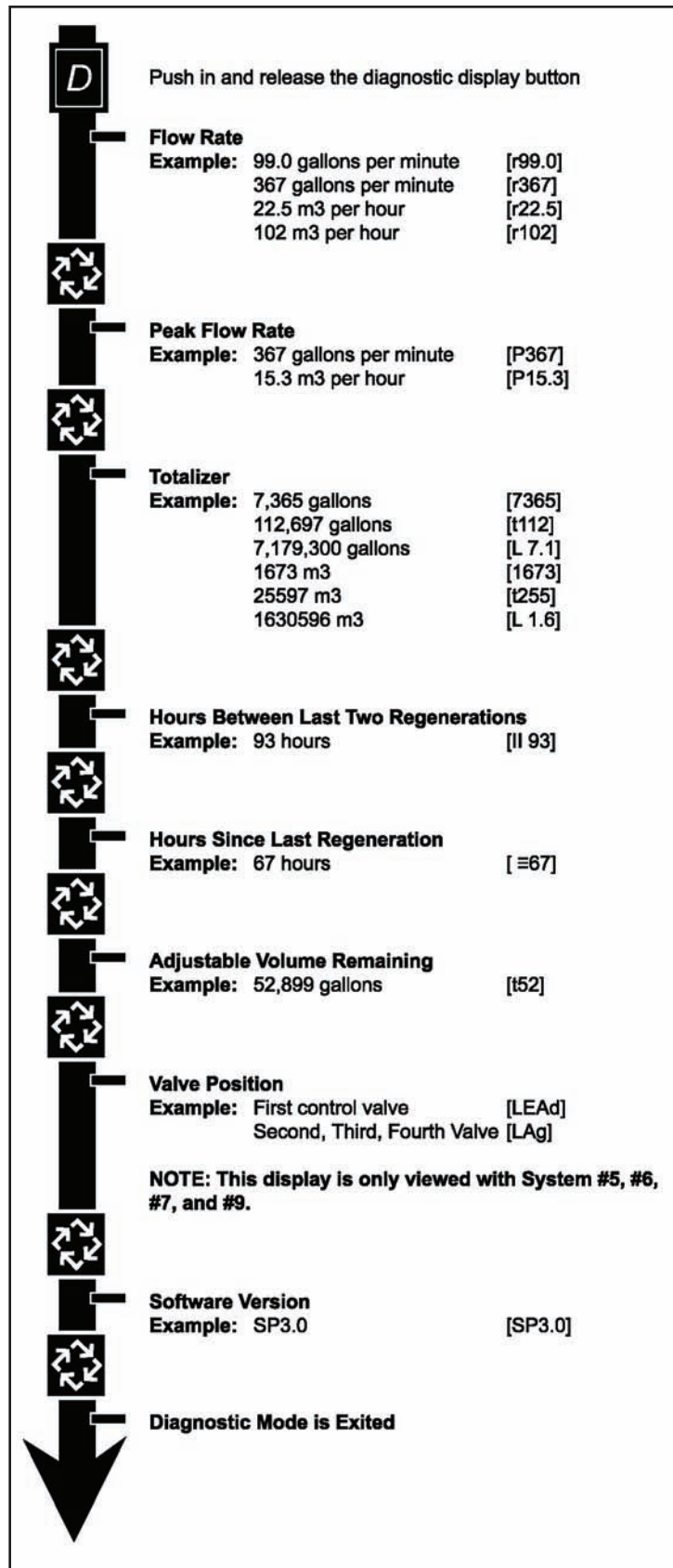

Water Softener Diagnostic Programming Guide:

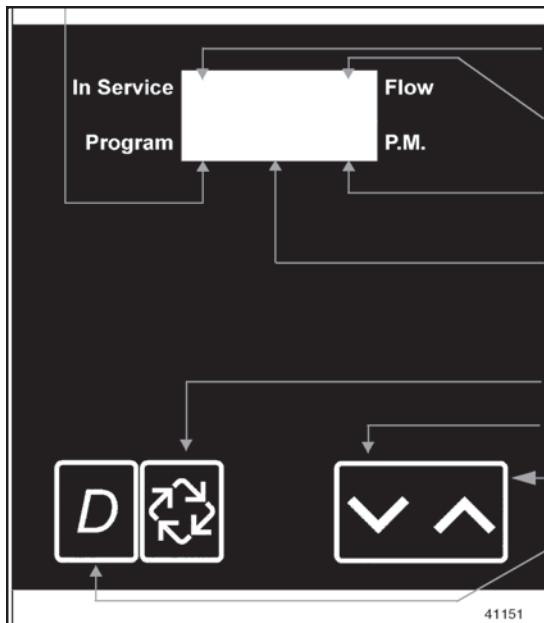

- Water softener extra cycle button
- Water softener set down button
- Water softener set up button
- Water softener diagnostic button

When the water softener diagnostics mode is entered, all available water softener displays are viewed as needed. Depending on current option settings, some water softener displays cannot be viewed.

Water Softener Overview Diagnostic Mode:

The current water softener diagnostic will be displayed until the water softener extra cycle key is pressed. There is no time limit on each display. The water softener timer will display local information not the water softener information. In the event of water softener regeneration occurring while displaying diagnostics, the regeneration step and time remaining will be displayed. When the water softener regeneration has been completed, the water softener display will return to diagnostic.

Water Softener Entering and Exiting Diagnostic Mode:

Push and release the water softener "D" button to enter. Pressing the water softener extra cycle button will move to the next water softener diagnostic to be displayed. Push the water softener extra cycle button once per display until all water softeners are viewed. The water softener diagnostic mode is exited and normal water softener operation resumes. Pressing the water softener diagnostic button while in the diagnostic mode will cause the water softener to leave the water softener diagnostic mode and return to the normal time of day display.

1. Water Softener Flow Rate (Display code R):

The water softener flow rate for this particular timer will be calculated and displayed. The water softener flow rates will be calculated over the time between water softener pulses up to 20 seconds will be ignored. If the water softener display is flashing, the flow rate has exceeded the water softener range and will not calculate. The water softener display updates once per second.

Water softener display example r100

Water softener range = 0.0 - 99.9 GMP, 100 - 500 GPM

Water softener range = 0.0 - 99.9 m³/h, 100 - 113 m³/h

- Depress the water softener extra cycle button.

2. Water Softener Peak Flow Rate (Display Code P):

The water softener peak flow rate since the last water softener regeneration will be captured. Reset the water softener to zero by holding up and down keys for 5 seconds during the water softener peak flow display.

Water softener display example P100

Water softener range = 0.0 - 99.9 GMP, 100 - 500 GPM

Water softener range = 0.0 - 99.9 m³/h, 100 - 112 m³/h

- Depress the water softener extra cycle button.

Water Softener Diagnostic Programming Guide:

3. Water softener totalizer (Display Code T = x 1,000, L = x 1,000,000)

The water softener total volume of treated water that passes through a meter will be counted to a maximum limit of 99,999,999 gallons of m³. Reset the water softener to zero by holding the up and down buttons for 5 seconds during the water softener totalizer display.

Water softener ranges, no display code, 0 to 999 = 0 - 9,999

Water softener ranges, display code (+) F - 10 to F999 = 10,000 - 999,999

Water softener ranges, display code (L) L - 1.0 to L99.9 = 1,000,000 - 99,999,999

- Depress the water softener extra cycle button.

4. The Water Softener Hours Between Last Two Regenerations (Display Code 11):

The hours between the last two water softener regenerations will be saved and displayed.

Water softener example 11 93

Water softener range = 0 to 999 hours

- Depress the water softener extra cycle button.

Water Softener Diagnostics Display Definitions and Examples:

Flow Rate

r = Display Code
Range = 1 - 99.9



Range = 100 - 500



Peak Flow Rate

P = Display Code
Range = 0 - 500



Totalizer

L = Display Code (X 1,000,000)
Range = 1,000,000 - 99,999,999



t = Display Code (X 1000)
Range = 10,000 - 999,999



No Display Code
Range = 1 - 9,999



Hours Between Last Two Regenerations

II = Display Code
Range = 1 - 199



Hours Since Last Regeneration

≡ = Display Code
Range = 1 - 199



Adjustable Volume Remaining

L = Display Code (X 1,000,000)
Range = 1,000,000 - 2,900,000



t = Display Code (X 1000)
Range = 10,000 - 999,999



No Display Code
Range = 1 - 9,999

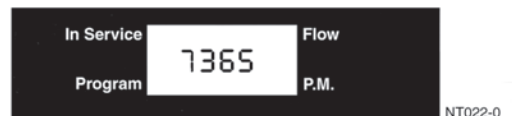

Valve Position

No Display Code (Lead or Lag)



Software Version

SP = Display Code



Water Softener Network Timer System Wiring Diagrams:

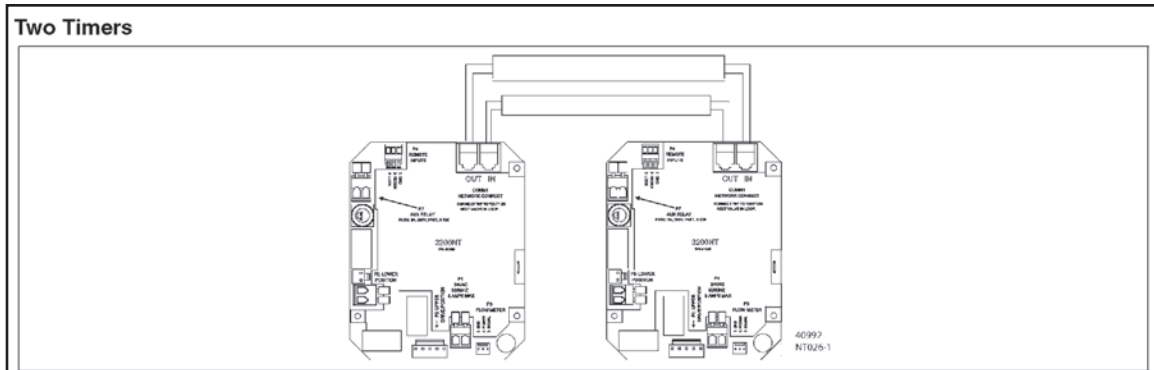

Figure 8: Network Timer System Wiring Diagram for System 5, 6, 7 and 9 Duplex

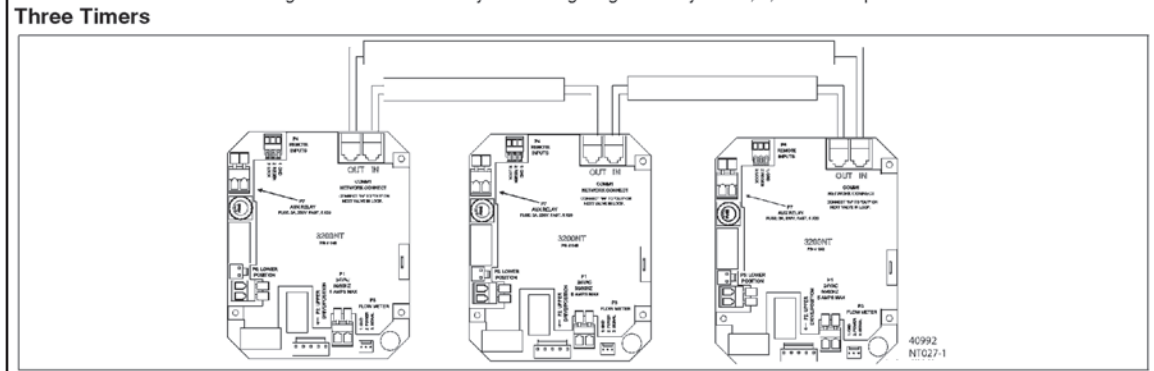

Figure 9: Network Timer System Wiring Diagram for System 5, 6 and 9 Triplex

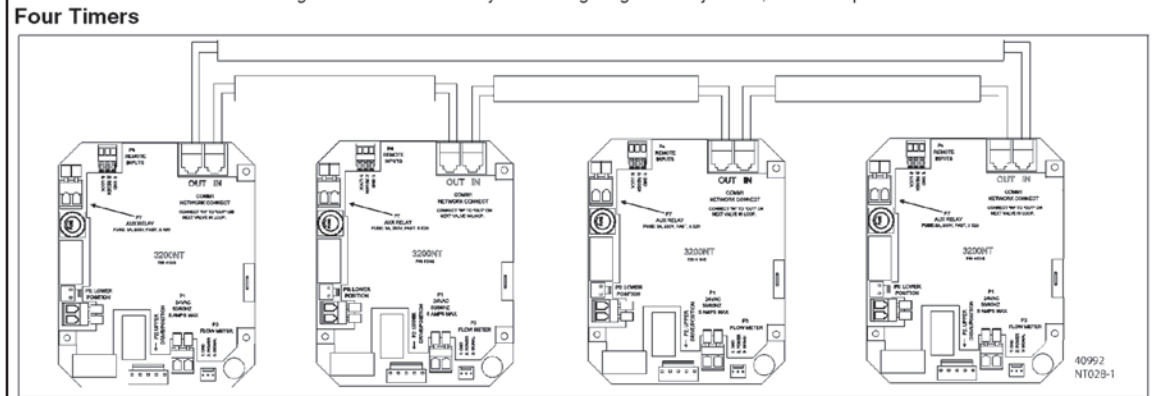

Figure 10: Network Timer System Wiring Diagram for System 5, 6 and 9 Quadplex

Interlocking 3200NT

NOTE: Use only 6-place, 4-conductor, RJ11 phone or extension cables.

1. Connect phone or extension cables first before programming.
 - System Type 7 and 6: flow meter cable must be connected to the timer programmed as the LEAd Timer.
2. A maximum cable length of 100' cable can be used between timers.
3. Always connect "IN" communication port to the "OUT" communication port of the next timer. Connect the last timer back to the first timer.

Water Softener Transformer, Phone Cable and Meter Cable Installation:

Transformer, Phone Cable and Meter Cable Installation

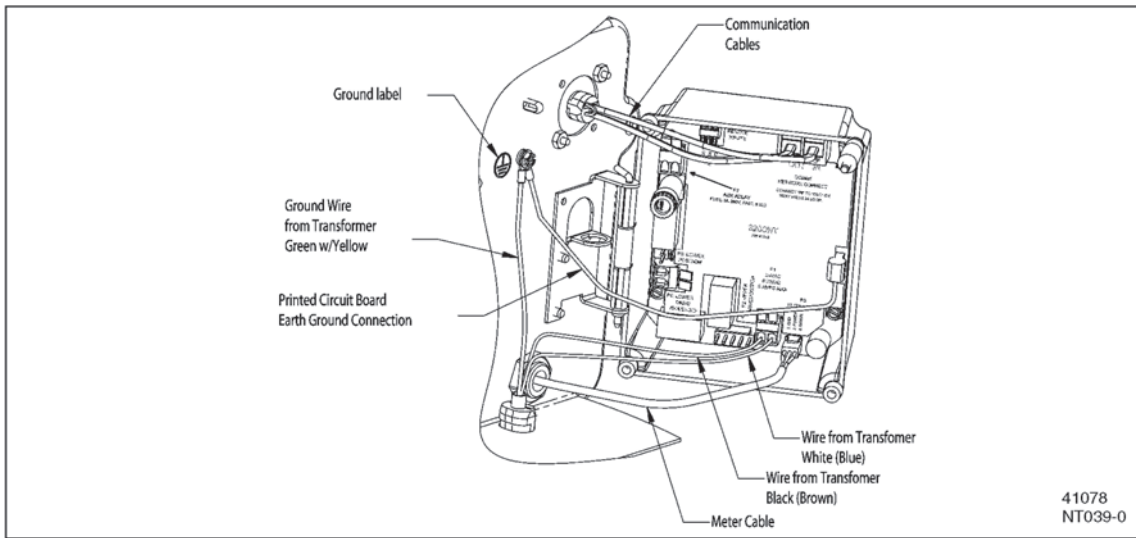

Figure 11: Installing Ground Wire on Transformer, 2750/2850/2900 Valves

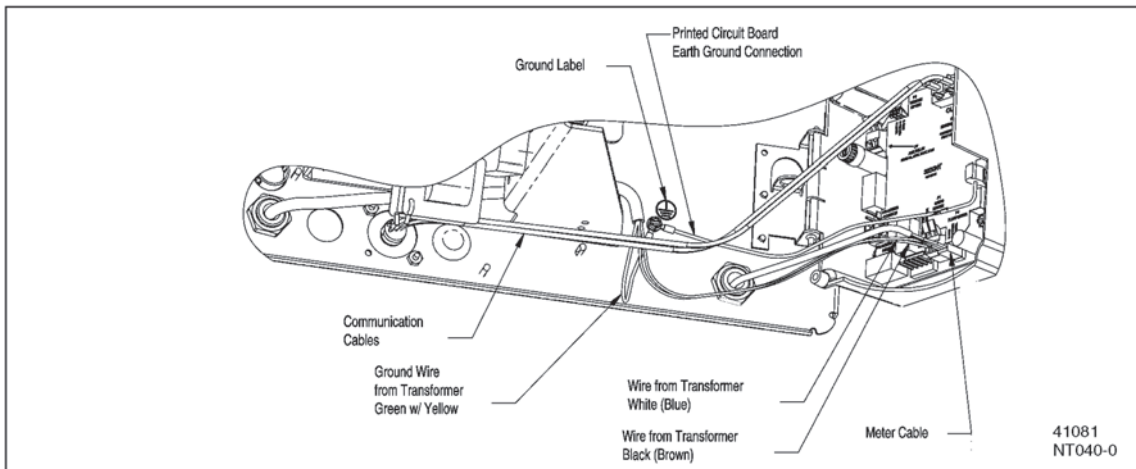

Figure 12: Installing Ground Wire on Transformer, 3150/3900 Valves

| <i>Item</i> | <i>Description</i> |
|-------------|------------------------------|
| A | ground label |
| B | ground wire from transformer |
| C | wires from transformer |

Installing and Grounding the Transformer

1. Locate the ground label (A) to find ground screw.
2. Remove the screw and attach the transformer ground wire (B).
3. Re-attach the screw.

Water Softener Trouble Shooting:

Communication Error

If a communication error is detected, **cErr** displays. It may take several minutes for all of the units in a system to display the error message.

- All units **In Service** remain in the **In Service** position.
- All units in standby go to **In Service**.
- Any unit in regeneration when the error occurs completes regeneration and goes to **In Service**.
- No units are allowed to start a regeneration cycle while the error condition exists.
- When the communication problem is corrected and the error no longer displays (it may take several minutes for all of the units in a system to stop displaying the error message), the system returns to normal operation.

NOTE: During the error condition the control continues to monitor the flow meter and update the remaining volume. Once the error condition is corrected all units return to the operating status they were in prior to the error and regeneration is queued according to the normal system operation. If reprogramming the unit in the Master Programming Mode clears the error, the volume remaining may be reset to the full unit capacity (i.e. as though it were just regenerated).

NOTE: System 4 units retain their normal display and do not display **cErr**.

| Cause | Correction |
|--|---|
| A. One or more units have a missing or bad communication cable. | A. Connecting the communication cables. |
| B. One or more units has a communication cable plugged into the wrong receptacle. | B. Connecting the communication cable as shown on the wiring diagrams. |
| C. One or more units is not powered. | C. Powering all units. |
| D. One or more of the units programmed as a stand alone system 4tc, 4FI or 4Fd and one or more units programmed as a multi-unit system 5FI, 6FI, 7FI or 9FI. | D. Programming the units for the same system type in the Master Programming Mode. |
| E. All of the units programmed as LAg. With no unit programmed as a LEAd (there is no unit to start the communications). | E. Programming the units correctly in the Master Programming Mode. |

Water Softener Programming Trouble Shooting:

Programming Error

Timers display **PErr** when a programming error occurs.

- If multiple timers are programmed as LEAd, **PErr** displays on all units.
- If multiple timers are programmed with different system types, feed water hardness, regeneration day override and line frequency, a **PErr** will be displayed.
- All units **In Service** remain in the **In Service** position.
- All units in standby go to **In Service**.
- Any unit in regeneration when the error occurs completes regeneration and goes to **In Service**.
- No units are allowed to start a regeneration cycle while the error condition exists.
- When the problem is corrected and the error no longer displays (it may take several minutes for all of the units in a system to stop displaying the error message), the system returns to normal operation.

NOTE: During the error condition the control continues to monitor the flow meter and update the remaining capacity. Once the error condition is corrected all units return to the operating status they were in prior to the error and regeneration is queued according to the normal system operation. If reprogramming the unit in the Master Programming Mode clears the error, the volume remaining may be reset to the full unit capacity (i.e. as though it were just regenerated).

NOTE: System 4 units retain their normal display and do not display **PErr**.

| Cause | Correction |
|--|--|
| A. One or more timers are programmed as System type different from the LEAd unit. | A. Programming the units correctly in the Master Programming Mode. |
| B. More than one timer is programmed as the LEAd unit. | B. Programming the units correctly in the Master Programming Mode. |
| C. One or more timers are programmed with different hardness, day override or line frequency values. | C. Program these values to be the same on all units. |

Simultaneous Communication and Programming Errors

If both a communication and programming errors occur simultaneously, the communications error (**cErr**) has precedence and masks the programming error (**PErr**). When the communications error (**cErr**) is corrected, the programming error (**PErr**) displays until corrected.